

# THE "FUEL" CYCLE"

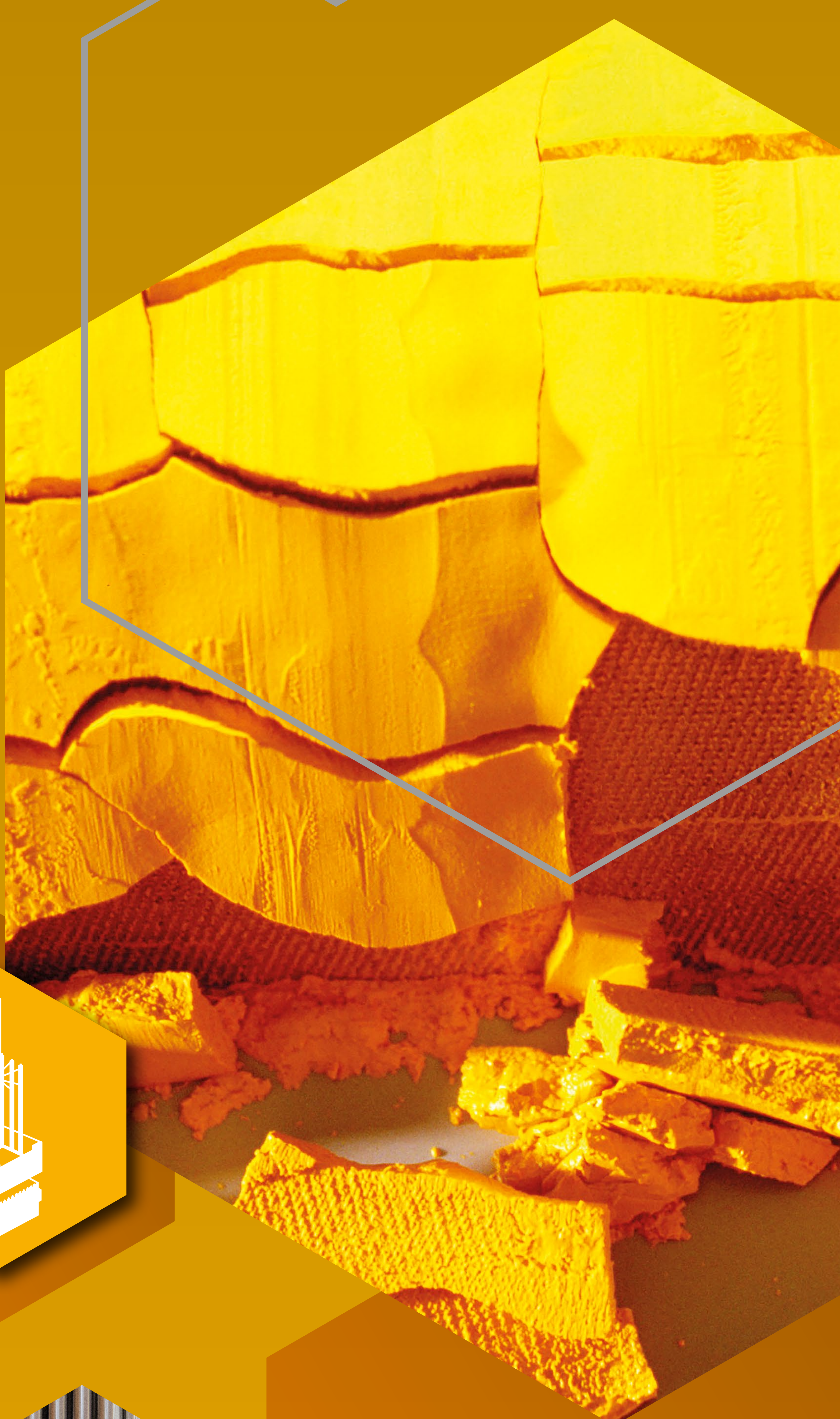

9.1

Design: ASN and IRSN Communications Departments - May 2022  
Graphic design and production: www.kazoar.fr - Pictograms: Freepik, Kazoar - Photos: Lesage Philippe/Orano, Eric Larrayadiou/Orano  
Reproduction prohibited without the agreement of ASN/IRSN. For further information: contact@irsn.fr





# THE "FUEL CYCLE"

# FROM THE MINE TO WASTE

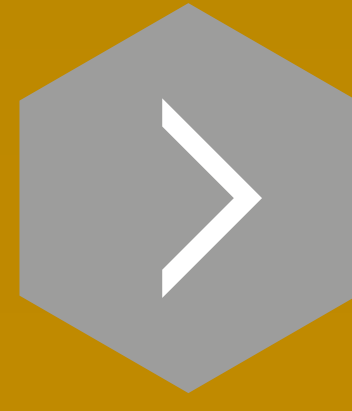

The fuel used in nuclear power plants is made from uranium ore. In France, once it has been used, some of the fuel material becomes waste, while the rest can be recycled.



## THE "FUEL CYCLE"



### URANIUM ENRICHMENT

Only uranium-235 is fissile and therefore useful for the operation of nuclear power plants. Natural uranium contains less than 1% uranium-235. For the French nuclear power plants, uranium has to be converted to UF6 before it can be enriched to the 3 to 5% of uranium-235 required for the final fuel.

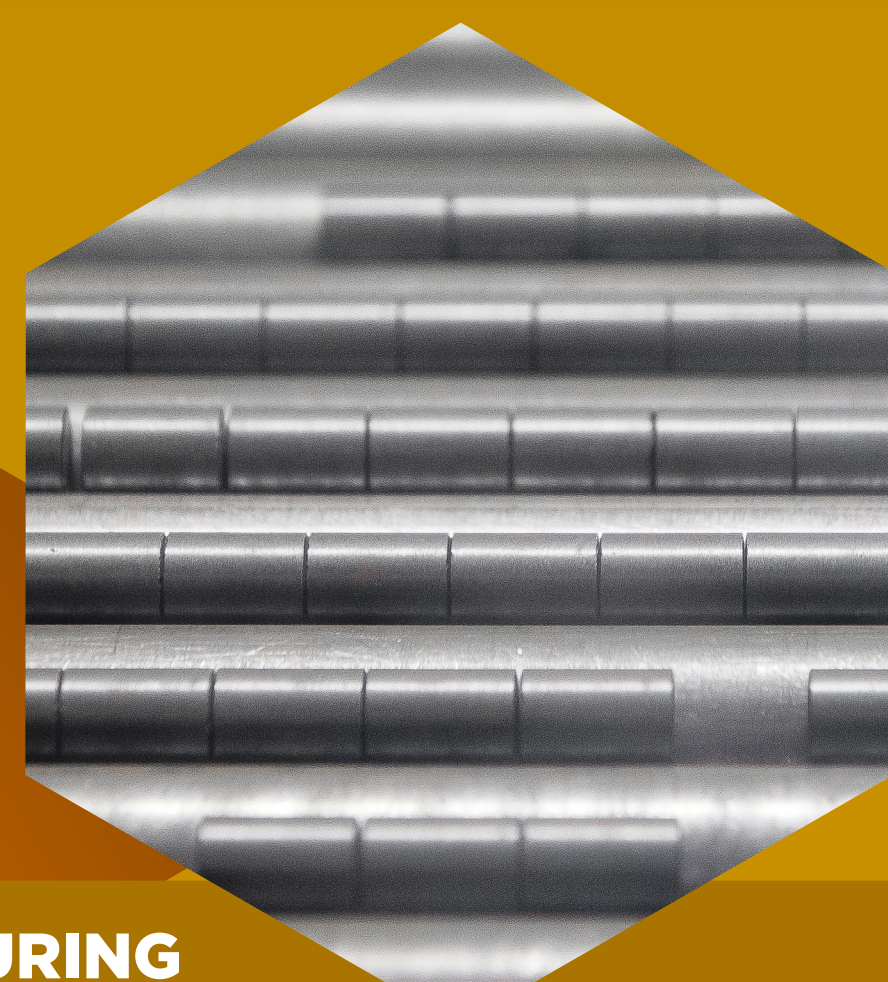

### MANUFACTURING MOX FUEL

Plutonium is mixed with uranium and compressed to form MOX fuel pellets. The pellets are stacked in tubes assembled in square bundles to form the final fuel.

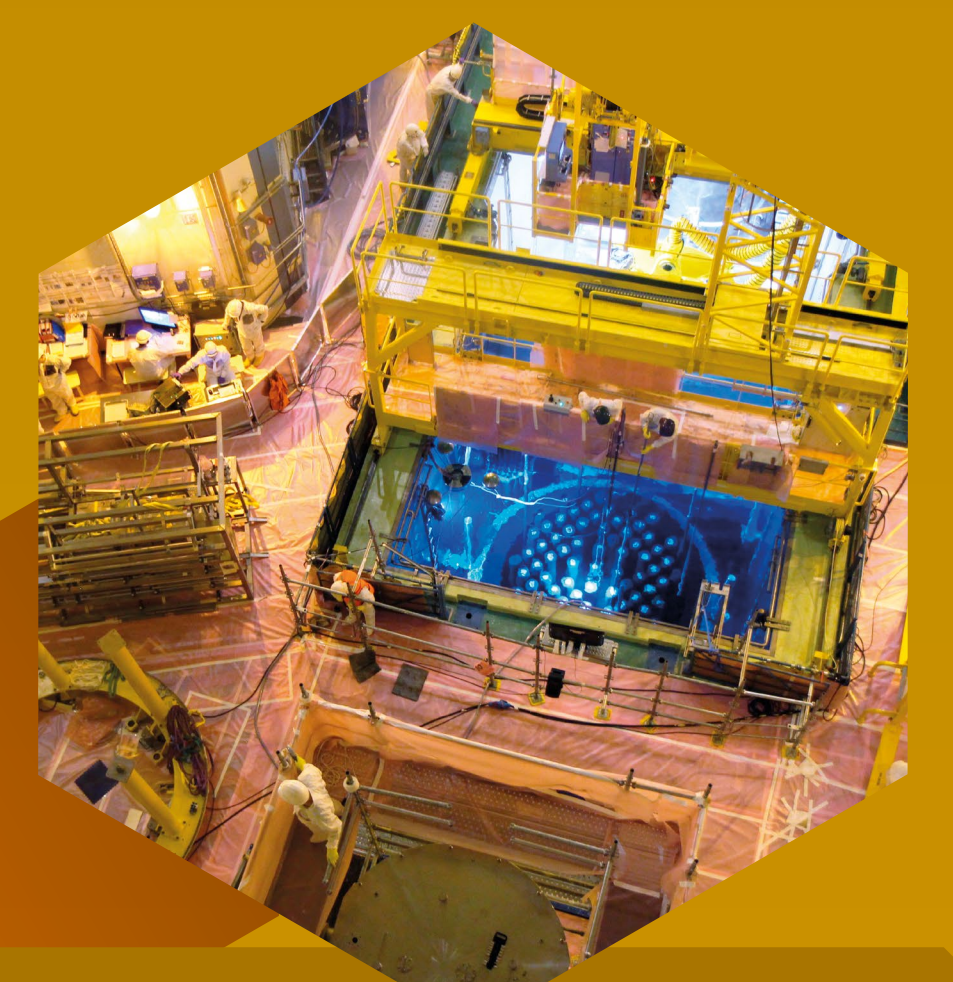

### IN THE REACTOR

More than 200 fuel assemblies are arranged in the reactor vessel to form the core. One third of the assemblies are renewed every year for 900 MWe reactors and every 18 months for 1,300 MWe reactors.



### URANIUM MINES

Most of the time, uranium is extracted from pitchblende. From this raw ore, a concentrated uranium powder is produced, known as "yellow cake". Tailings and waste rock remain on site. Today, the French mines have been closed and uranium comes from abroad.

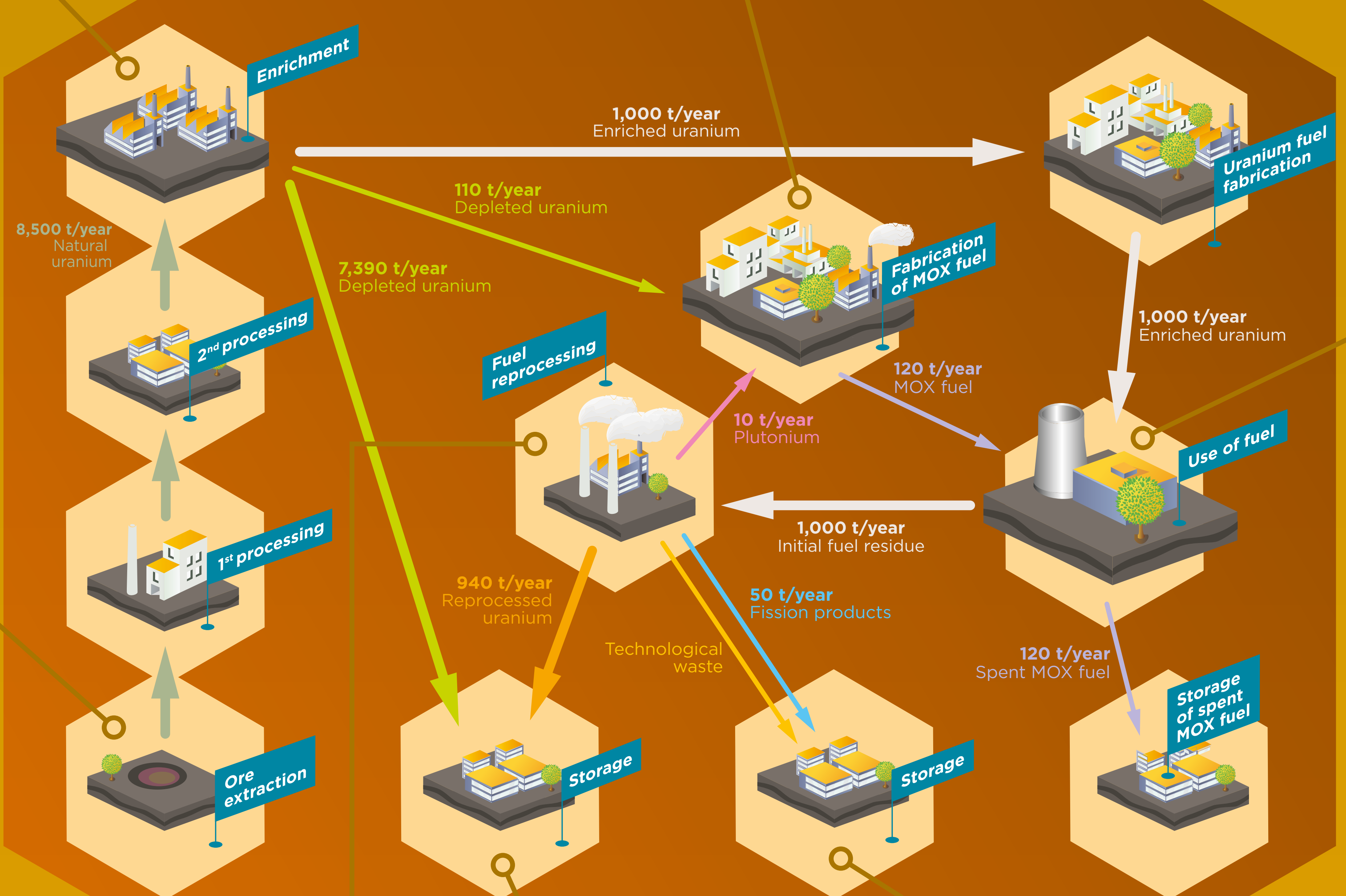

### REPROCESSING

The fuel assemblies are sheared and chemically dissolved. The uranium and plutonium that can be used to manufacture new fuels are extracted. Plutonium is a component of MOX fuel.

### COOLING

Nuclear reactions continue to heat the pellets even when the assemblies are spent and removed from the reactor vessel. So they must be continuously cooled in a pool connected to a water circulation system for several years before they can be reprocessed.

### STORAGE OF REPROCESSED URANIUM

Uranium from reprocessed fuel is no longer recycled in France and is stored at the Pierrelatte site.

### DISPOSAL

Fission products and actinides, radioactive waste from reprocessing, are incorporated into molten glass, which is then poured into hermetically sealed stainless steel containers. These containers are then stored until a final disposal site is found.

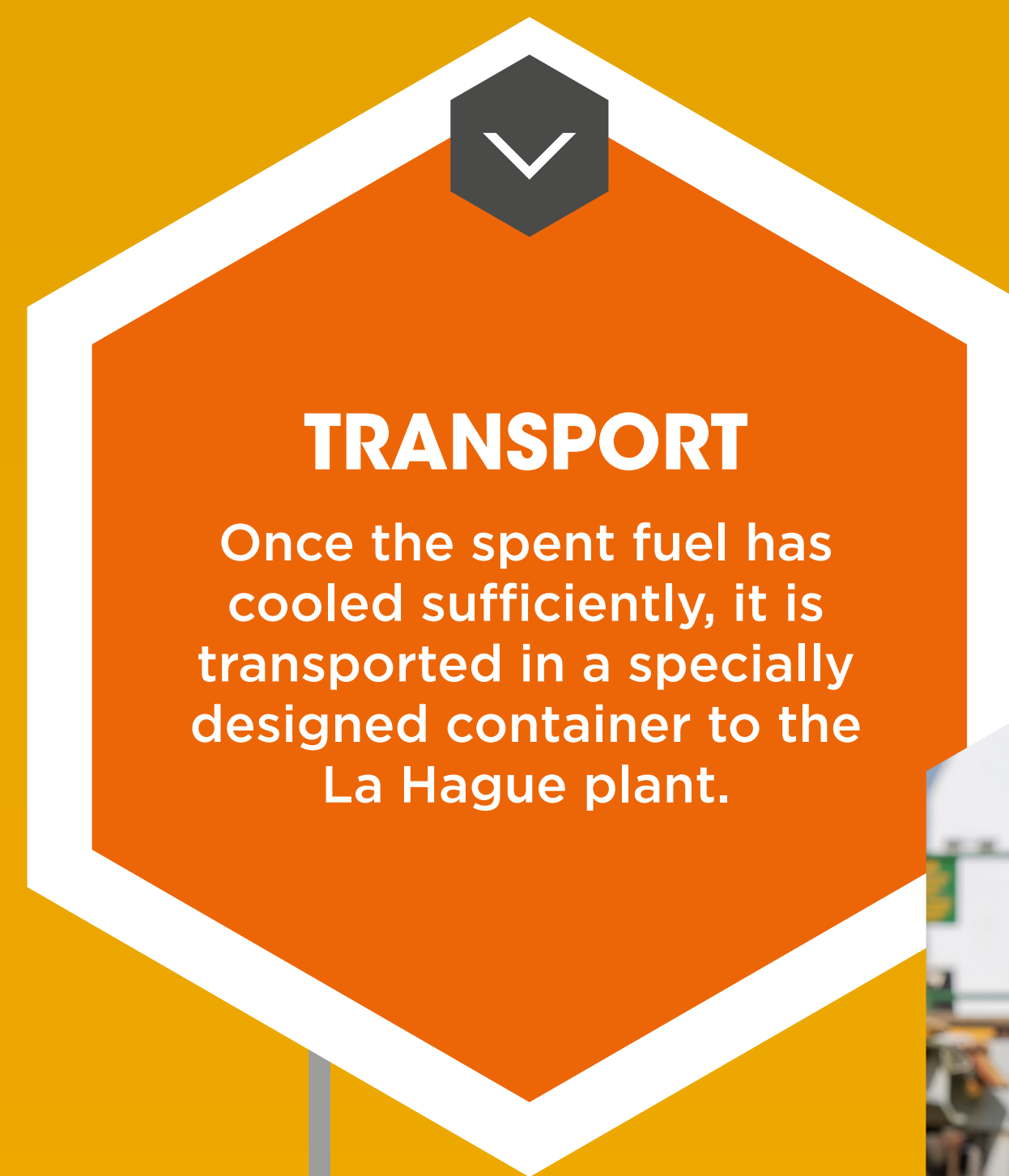
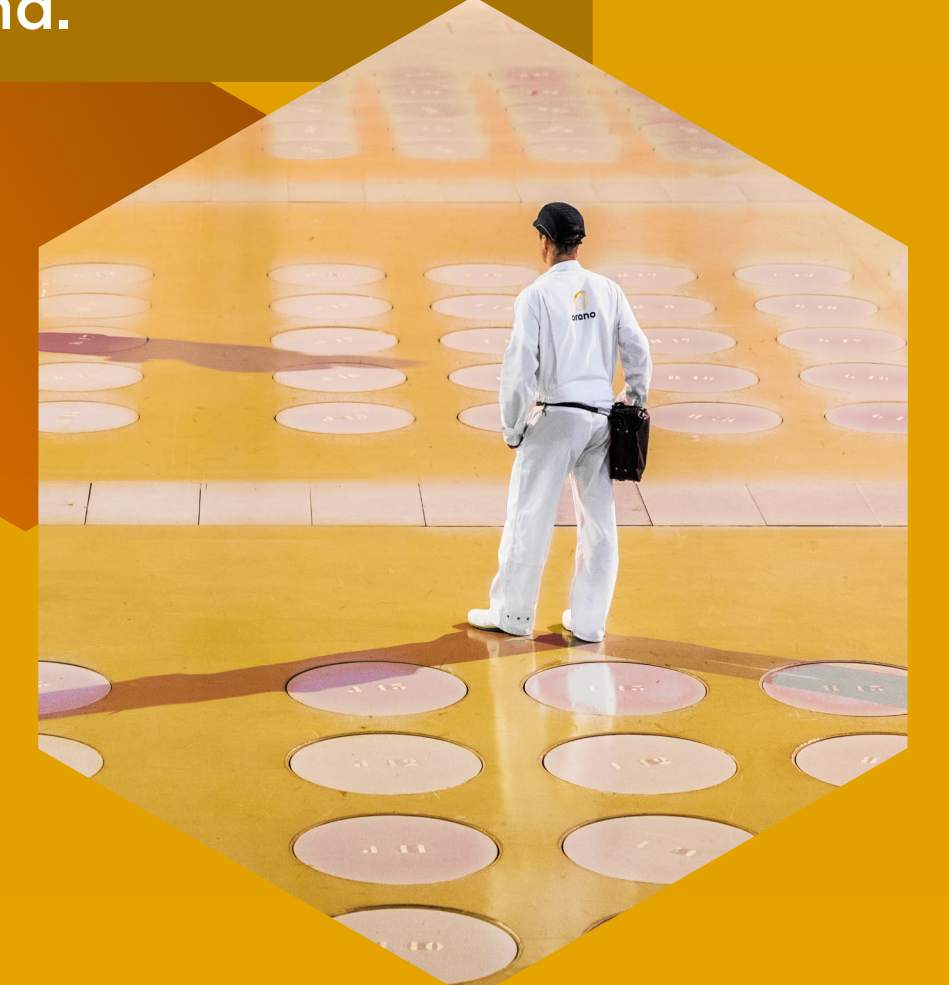

### TRANSPORT

Once the spent fuel has cooled sufficiently, it is transported in a specially designed container to the La Hague plant.







# THE "FUEL CYCLE"

# URANIUM MINES

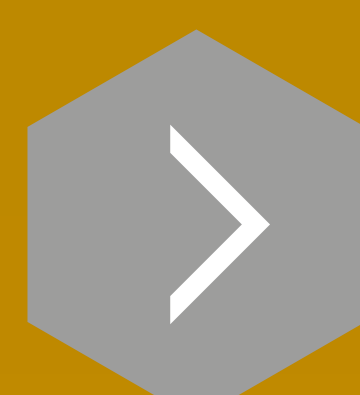

The uranium used in France today is sourced exclusively from abroad. But France operated mines for over 50 years, producing waste rock and tailings that still need to be managed.

## URANIUM MINES AROUND THE WORLD

### FORMER MINES IN FRANCE

Uranium was mined in France between 1948 and 2001, with production peaking in the 1980s. There are around 250 former mining sites, spread over 27 départements, which produced a total of 76,000 tonnes of uranium.

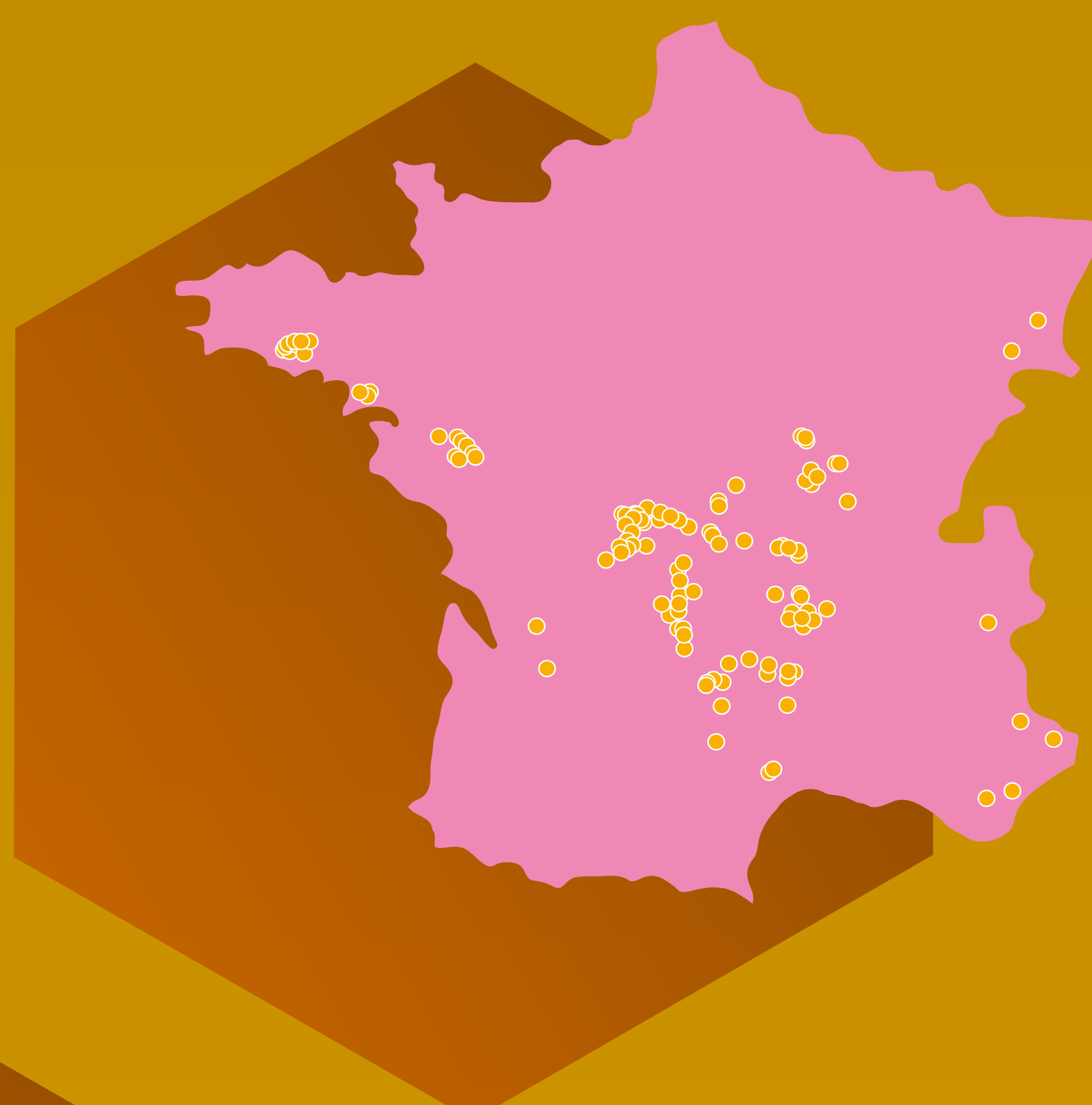

**More details**  
on mines in France

### ORANO'S MINES ABROAD

Cogema, now Orano, has invested in high-grade ore mines abroad, for example in Niger and Canada.

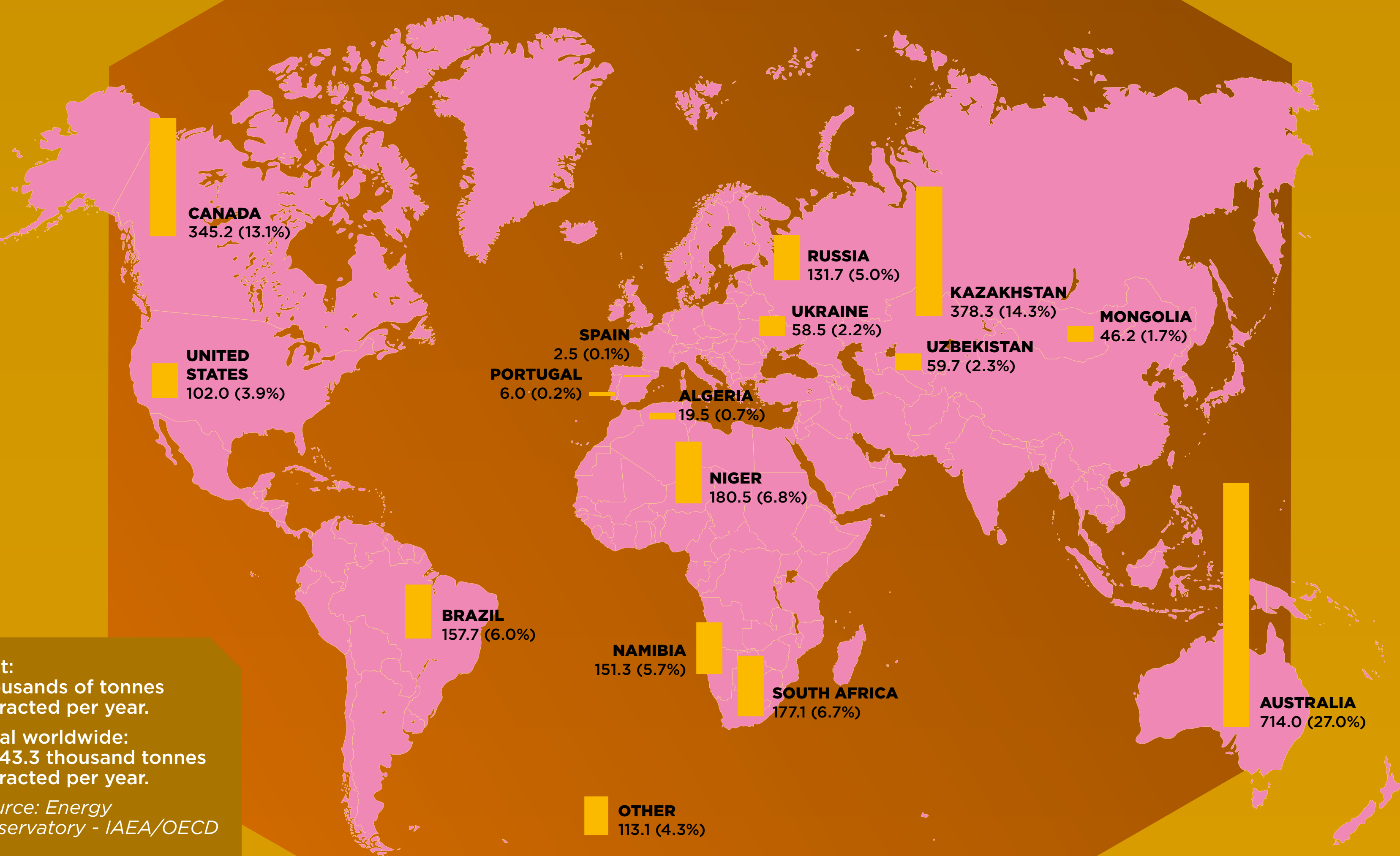

## THE MOTHER LODE

Uranium veins have formed over the millennia as a result of water flowing through faults, cracks and the open surfaces of granitic formations. The water carried the uranium atoms with it, depositing them where the chemical conditions were favourable.

That's why there are so many old mines in the Massif Central and Brittany, where the granite is rich in uranium.

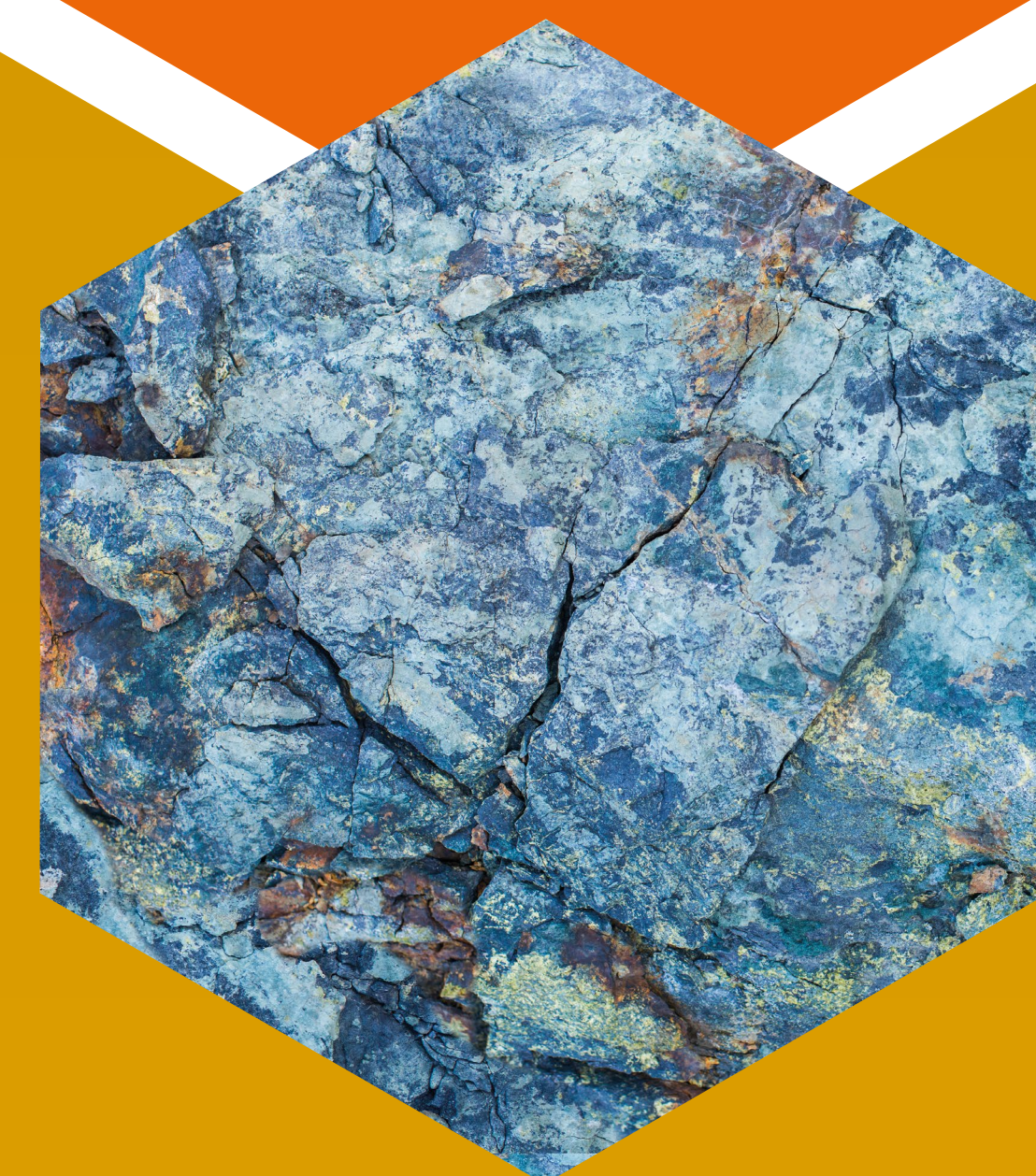

## How much does uranium cost?

Uranium is not a very expensive resource. In 2017, 1 kg of raw uranium (excluding processing) cost 80 euros. For comparison, 1 kg of silver was worth around 500 euros and 1 kg of gold, 30,000 euros.

The price of uranium fluctuates in line with market trends, but also with incidents such as the flooding of the Cigar Lake mine in Canada and the fire at the Olympic Dam mine in Australia in 2007.

Uranium mining can present health risks for miners, and tailings left on site can pose risks for the local population.

## RISKS FOR MINERS

Among other risks, miners extracting uranium can be exposed to radon, a radioactive gas emanating from the rocks and stagnating in the galleries. The Mining Code regulates their work.

## STUDIES ON MINERS

IRSN carried out research on almost 5,000 miners to determine the consequences of radon exposure, and compared the results with numerous other studies.

Differences in lung cancer mortality rates as a function of radon concentrations were quantified.

For example: exposure of around 1,000 Bq/m<sup>3</sup> per year for 25 years doubles the risk of developing lung cancer.



## DEBATE THE ISSUE OF MINE TAILINGS

Uranium mining in France has resulted in the production of several million tonnes of radioactive waste rock and tailings. At times, they may have been used as fill or building materials.

Today, we cannot move tailings, so they have to be monitored. Actions are taken to map sites and assess risks.

Regulations have changed: It is now forbidden to use tailings for construction.





# THE "FUEL CYCLE"

# FUEL FABRICATION

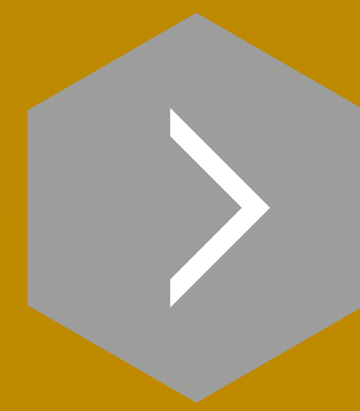

Once out of the mine, the uranium undergoes a number of physical-chemical treatments before finally being converted into uranium dioxide pellets. The pellets are stacked in "rod claddings" that make up the "assemblies".

## A CASCADE OF CHEMICAL TRANSFORMATIONS...

Uranium extracted from mines, concentrated in the form of "yellow cake", cannot be used in French nuclear reactors.

To become fuel, it has to undergo a number of operations. First, the *yellow cake* is dissolved in acid and then purified. Calcination produces uranium trioxide powder ( $UO_3$ ), which is then transformed into uranium tetrafluoride ( $UF_4$ ).

These operations are carried out at Orano's Malvézi plant near Narbonne.

At the Philippe Coste plant at Tricastin in the Drôme,  $UF_4$  is then converted into uranium hexafluoride ( $UF_6$ ), which is then transformed from a solid into a gas to enrich it in isotope 235. Uranium oxide ( $UO_2$ ) pellets are then produced from enriched uranium powder.



## ASSEMBLY

Over 200 rods are assembled in grids into which a control bar is inserted to control the chain reaction.

## ...TO MANUFACTURE URANIUM OXIDE PELLETS...

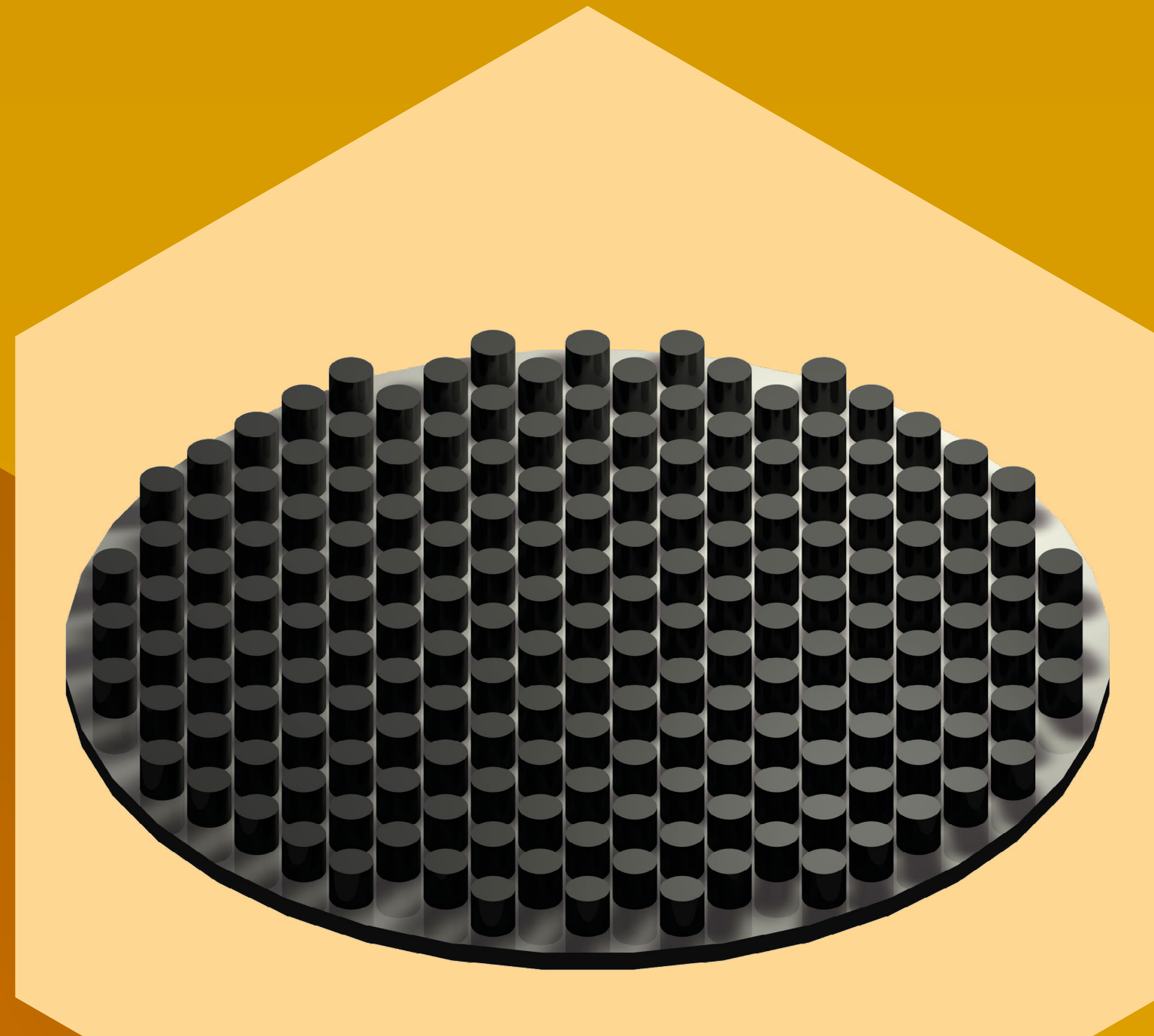

Actual size:  
1 x 1 cm.

## ...AND RODS CLADDED WITH ZIRCALOY...

Zircaloy is an alloy that allows neutrons to pass through, but unfortunately it can oxidise at high temperature to form hydrogen.

In the event of an accident, the quantity of hydrogen produced is such that it could lead to a risk of explosion.



## URANIUM CHEMISTRY IS NOT WITHOUT RISK

Uranium hexafluoride is radioactive. What's more, it's a highly toxic product: it reacts with water to form uranyl fluoride ( $UO_2F_2$ ) and hydrofluoric acid (HF).

This reaction is rapid and strong, and is accompanied by the emission of irritating and suffocating hydrofluoric acid fumes. These risks also need to be managed.





# THE "FUEL CYCLE"

# FUEL REPROCESSING

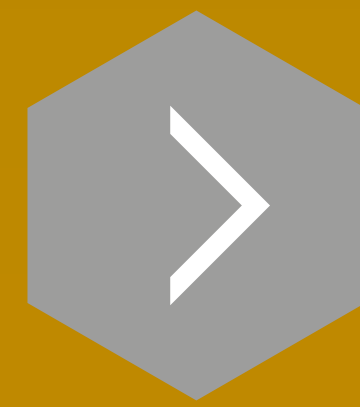

In France, only part of the **spent fuel** from nuclear power plants becomes **waste**. The rest can be **recycled** to make new fuel.

## 1. REACTOR: SPENT FUEL

The uranium-235 concentration in fuel pellets decreases as they are irradiated. These isotopes are transformed into artificial radioactive elements. Each fission reaction breaks up an atom, replacing it with two atoms known as fission products.

When a neutron strikes a uranium-238 atom, the atom can absorb the neutrons, forming heavy actinides such as americium, neptunium or plutonium.

Plutonium is also fissile and, in France, it can be used to make MOX fuel. The plutonium content of spent fuel is around 1%. Reprocessing separates these different products.

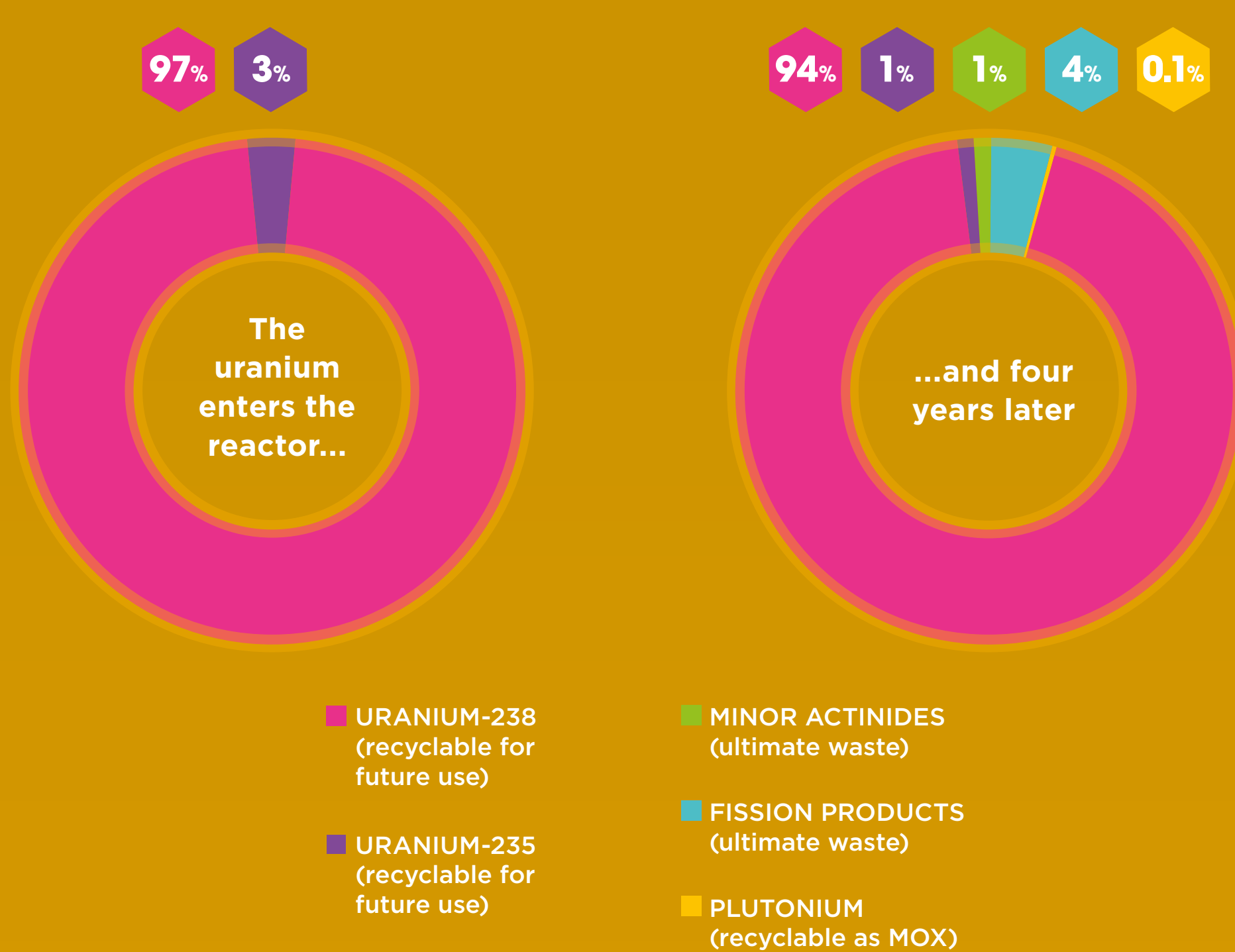

## 2. THE POOL: HOT! HOT! HOT!

Radiation from the artificial radioactive elements in the spent nuclear fuel cause it to heat up intensely.

At end of life, the fuel assemblies are removed from the reactor using automated equipment and stored on site in a pool to be cooled down.

The heat will then gradually decrease.



Decay curve for the power of spent fuel assemblies over time

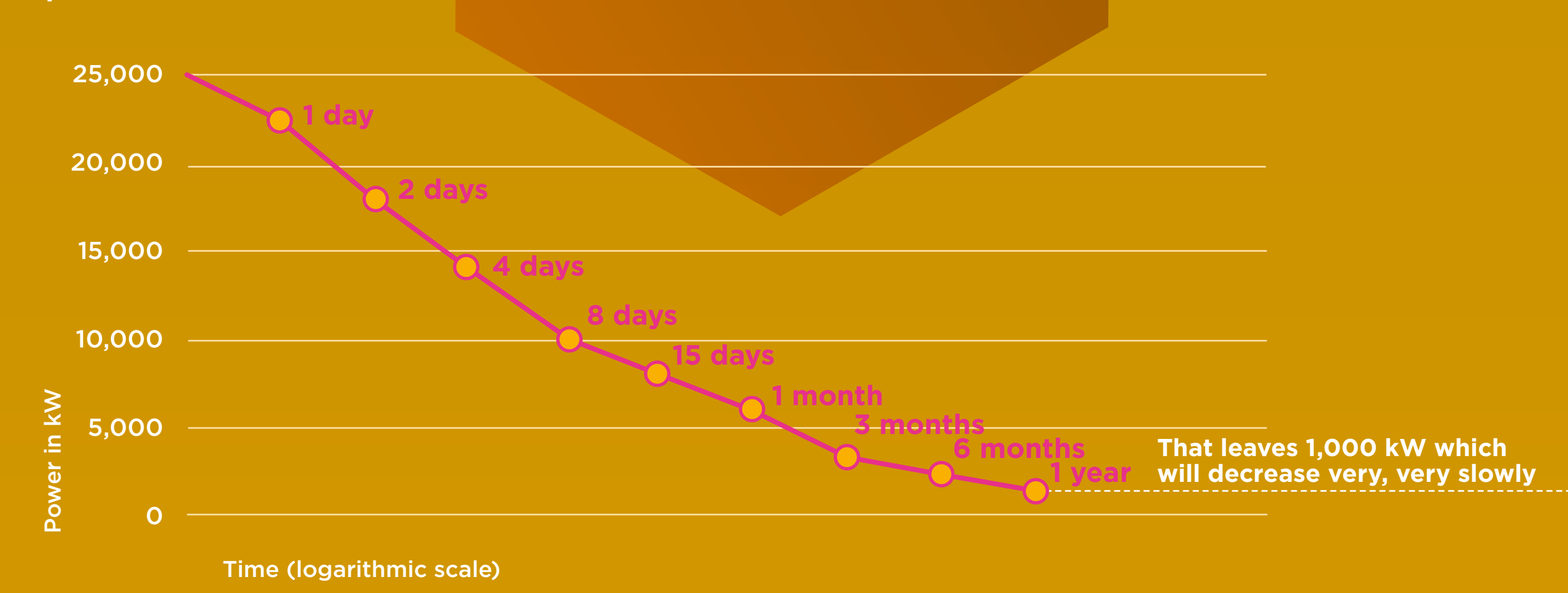

## 3. TRANSPORT AND STORAGE

When the fuel has cooled sufficiently, it is removed from the pool of the reactor, placed in specially designed packages and transported to the La Hague plant, where it is stored again in a pool before potential reprocessing.

One of the pools at La Hague contains the equivalent of 40 nuclear reactor cores. A height of 20 metres of water protects workers from ionising radiation.

## 4. RECYCLING: THE SECOND LIFE OF FUEL

Uranium remains in the spent fuel and is extracted to be reused and re-enriched.

Spent fuel also contains fissile plutonium, which can be used in a nuclear reactor. It is mixed with uranium to make a "recovered" fuel called MOX (mixed oxide).

The fuel most commonly used in France, made with uranium alone, is called UOX (uranium oxide).



## DEBATE DOES MOX HAVE ANY DISADVANTAGES?



To make MOX fuel, plutonium contained in spent fuel is reused. This avoids disposing of it as waste and saves uranium resources.

In the event of an accident, the fission products from MOX fuel are more dangerous than those from UOX.



Chemically, plutonium is also highly toxic for workers, requiring additional protective measures.

From a security point of view, plutonium in purified form can be the target of theft in order to be used in weapons.





THE "FUEL CYCLE"

# TRANSPORT OF RADIOACTIVE SUBSTANCES

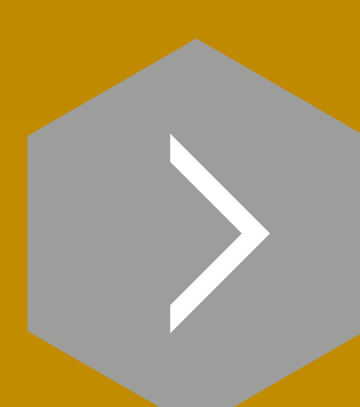

In France, around **one million packages** of radioactive substances are transported every year. Transport relating to the "fuel cycle" accounts for only a small proportion of this (around 10% of the packages transported) but presents the greatest safety challenges (particularly for the transport of spent fuel).



## PACKAGES DESIGNED FOR STRENGTH

There are several categories of package for transporting radioactive substances, defined according to the quantity of radioactive substances to be transported (the activity of the contents) or their dilution in the totality of the materials to be transported (the mass activity of the contents).

Of these different categories of radioactive substance packages, category A covers substances of intermediate radioactivity and category B covers those of high radioactivity, such as spent fuel.

Engineers have designed packaging that can withstand different types of incidents and accidents.

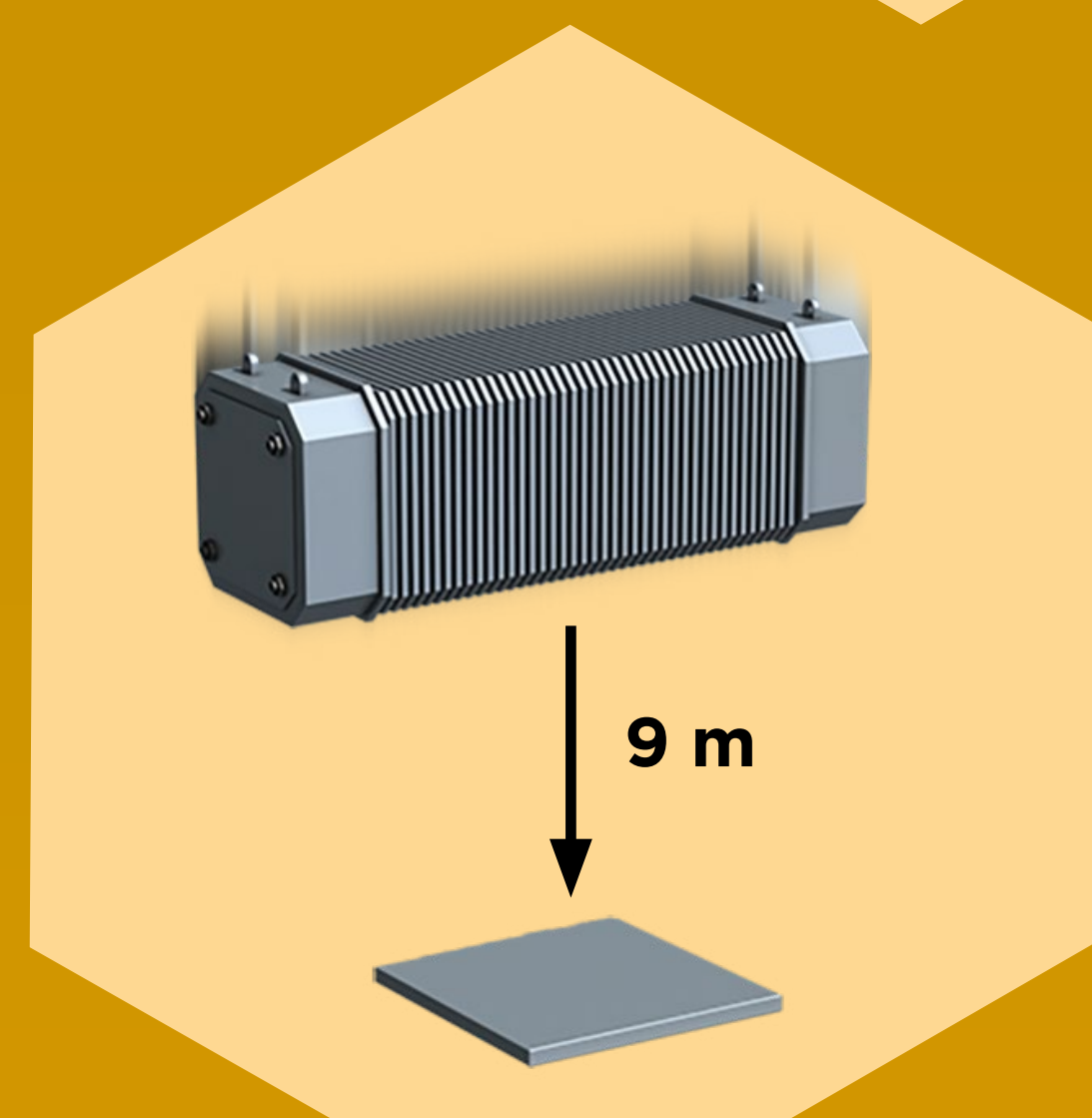

Drop resistance test

| Examples of regulatory tests                  |  |   |  |
|---|--|---|--|
| Category A (intermediate level radioactivity) | Resistant to water spraying to simulate a severe storm | Resistant to penetration by a 6 kg bar dropped from a height of 1 m | Resistant to free fall of the package from a height of up to 1.2 m |
| Category B (high level radioactivity)         | Can withstand submersion to a depth of 200 m           | Resistant to free fall of 9 m and a drop of 1 m onto a punch        | Resistant to a fire test of 800°C for 30 minutes                   |

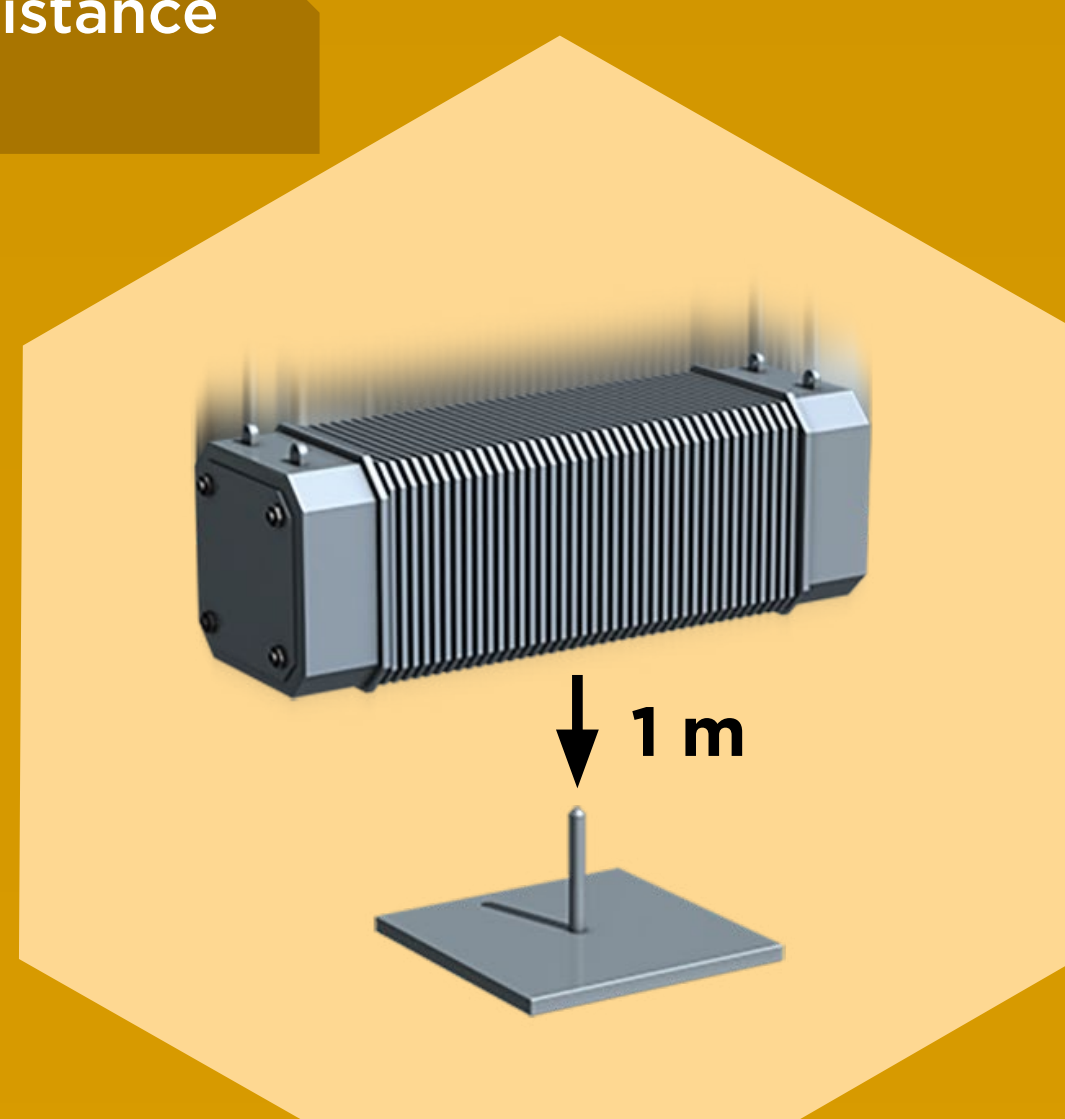

Punch resistance test

## WHAT ABOUT LOW-LEVEL PACKAGES?

Even if they were to be completely destroyed in an accident, exposure of the public and responders would remain limited.



Fire resistance test

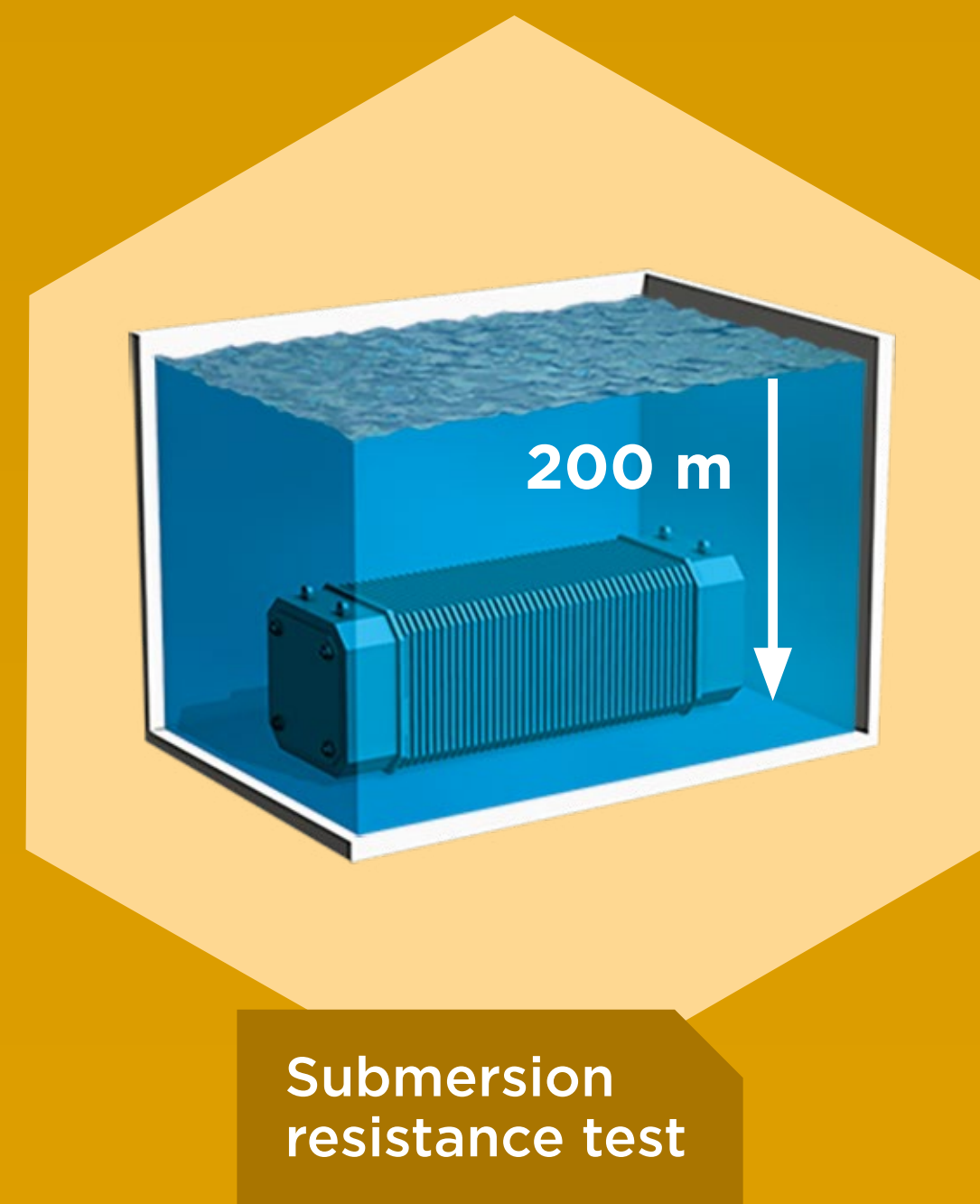

Submersion resistance test



## TRANSPORT SAFETY OF RADIOACTIVE SUBSTANCES

The company responsible for transport must comply with international regulations concerning the robustness of packaging containing radioactive substances, the reliability of transport operations and emergency preparedness.

Packages representing significant safety concerns must be approved by ASN, following technical assessment by IRSN.

In addition, it is important to make sure that:

- The operators and staff concerned are organised and trained to deal with any event that could occur;
- The traceability of transported radioactive materials is ensured and labelling is precise and standardised, providing clear information and instructions for those who would intervene in the event of an accident;
- Inspections and checks on compliance with these rules are carried out by ASN.



## DEBATE RISKS ASSOCIATED WITH TRANSPORT



Even if the packaging provides a high degree of radiation protection, the packages continue to emit radiation.

Packages can be transported by all modes of transport (road, rail, air, sea) and on public routes.

Some elected officials and non-governmental organisations denounce the risks of exposure for local populations, as well as the lack of information about the routes taken.



The risk of public exposure is low.

A person would have to spend ten hours, within two metres from a vehicle carrying high-level radioactive substances to be exposed to 1 millisievert, the annual regulatory limit for the public.

To prevent malicious acts, the most sensitive transport routes must remain confidential.

9.6

Design and production: [www.kazoar.fr](http://www.kazoar.fr) - Pictograms: Freepik, Kazoar - Illustrations: La-fabrique-creative/Bruno Bourgeois  
Reproduction prohibited without the agreement of ASN/IRSN. For further information: [contact@irsn.fr](mailto:contact@irsn.fr)